

Your New Pansat 700HC MPEG-2 Receiver

What is MPEG-2?

MPEG-2 is the next satellite TV adventure that many longtime C-band enthusiasts are embracing. Like early C-band, MPEG-2 is an array of programming you can see nowhere else. And best of all, MPEG-2 programming is totally free.

MPEG-2 signals are constantly changing. You might tune into a channel that was vacant yesterday and find feeds of popular major drama or comedy television series, sports, international programming and more. Channels that are here today may not be around tomorrow; or they might be on a different frequency. To make the most of what MPEG-2 has to offer, be sure to watch for these changes. To find the latest free-to-air offerings (including Transponder Frequencies, Symbol Rates and Polarity), go to the Resource Page on Skyvision's web site, <http://www.skyvision.com>.

How do I connect my MPEG-2 receiver?

Not all satellite receivers are exactly the same. However, the hookup diagrams should give you enough information to integrate your new MPEG-2 receiver into your existing system.

For a system with a C-band LNB only:

Connect the coax from your C-band LNB to the **LNB INPUT** on your MPEG-2 receiver. Connect a coax cable from the **LOOP OUT** output on the MPEG-2 receiver to the **C-BAND LNB IN** input on your analog or 4DTV receiver. Run a coax from **RF OUT** to your analog or 4DTV receiver, **ANTENNA IN**. If your TV has another coaxial or A/V input, you can use these instead of the coaxial to the **TV ANTENNA IN**.

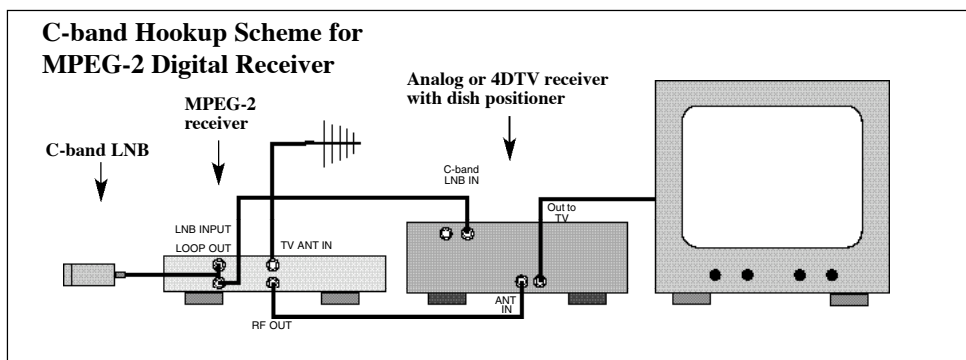

NOTE: If you have a 4DTV Sidecar, see the Skyvision insert, *Connecting Your 4DTV Digital Sidecar*, for connection instructions. Even in a system that includes an MPEG-2 receiver, the C- and Ku-band LNBs loop through the Sidecar as described in that insert.

- over -

C/Ku-band Hookup Scheme for MPEG-2 Digital Receiver

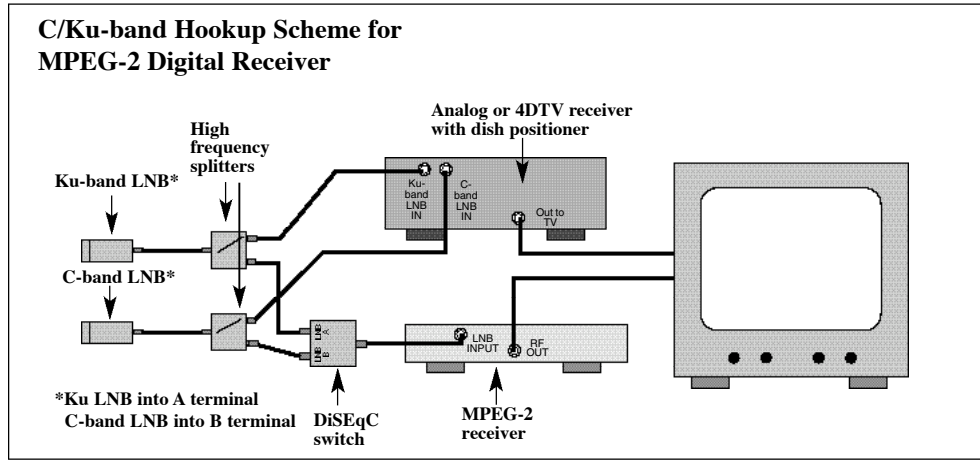

NOTE: If you have an analog receiver with only one LNB input and you have a C- and Ku-band LNB, you will need to place a C/Ku Switch between the LNBS (or the high frequency splitters) and the analog receiver.

For a system with C-band and Ku-band LNBS:

- 1) Use high-frequency splitters to split the incoming C- and Ku-band LNB signals. Be sure to hook the coax from your analog or 4DTV receiver to the output marked with the diagonal line (indicating passive one-way voltage flow) on each high-frequency splitter. Connect the coax from each splitter to the correct LNB input on the analog or 4DTV receiver (Ku-band splitter to Ku-band **L N B I N** and C-band splitter to C-band **L N B I N**).
- 2) Connect the other output on the high-frequency splitters to the A and B inputs on the DiSEqC switch, which will combine the C- and Ku-band signals and feed them to the MPEG-2 receiver through the **L N B I N P U T**.
- 3) If your television has more than one coaxial or A/V input, connect the MPEG-2 receiver to one of the inputs and your analog or 4DTV receiver to the other (both receivers will have a connector labeled **O U T T O T V** or **R F O U T**). If your television has one input, run a coaxial cable from the **R F O U T** connector on the MPEG-2 receiver to the **A N T I N** input on your analog or 4DTV receiver. Run a coaxial cable from **O U T T O T V** on the analog or 4DTV receiver to the input on your television.

How do I program my Pansat 700HC MPEG-2 receiver?

Press “Menu”

Arrow down to “Installation”; press “Enter”

Press Password “0000”

Arrow down to “Satellite Scan”; press “Enter”

Select “Scan Mode” using <> arrows

Arrow down to “Satellite Name”

Press “Enter” to scan

If using a DiSEqC switch, you must indicate for each satellite in “LNB Configure” which port on the DiSEqC switch is C-band and which port is KU-band. we recommend the Ku-band be the #1 or A port and C-band be the #2 or B port.