

# Your New Traxis DBS 1500 MPEG-2 Receiver

What is MPEG-2?

**M**PEG-2 is the next satellite TV adventure that many longtime C-band enthusiasts are embracing. Like early C-band, MPEG-2 is an array of programming you can see nowhere else. And best of all, MPEG-2 programming is totally free.

MPEG-2 signals are constantly changing. You might tune into a channel that was vacant yesterday and find feeds of popular major drama or comedy television series, sports, international programming and more. Channels that are here today may not be around tomorrow; or they might be on a different frequency. To make the most of what MPEG-2 has to offer, be sure to watch for these changes. To find the latest free-to-air offerings (including Transponder Frequencies, Symbol Rates and Polarity), go to the Resource Page on Skyvision's web site, <http://www.skyvision.com>.

How do I connect my MPEG-2 receiver?

**N**ot all satellite receivers are exactly the same. However, the hookup diagrams should give you enough information to integrate your new MPEG-2 receiver into your existing system.

**For a system with a C-band LNB only:**

Connect the coax from your C-band LNB to the **LNB IN** input on your MPEG-2 receiver. Connect a coax cable from the **LOOP OUT** output on the MPEG-2 receiver to the **C - B A N D LNB IN** input on your analog or 4DTV receiver. Run a coax from **RF OUT** to your analog or 4DTV receiver, **ANTENNA IN**. If your TV has another coaxial or A/V input, you can use these instead of the coaxial to the **RF IN**.

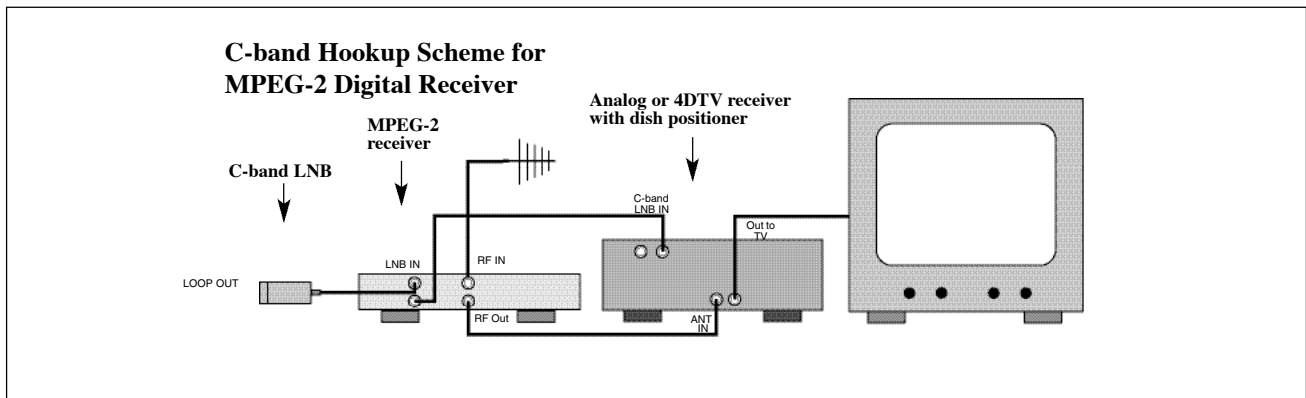

- over -

### C/Ku-band Hookup Scheme for MPEG-2 Digital Receiver

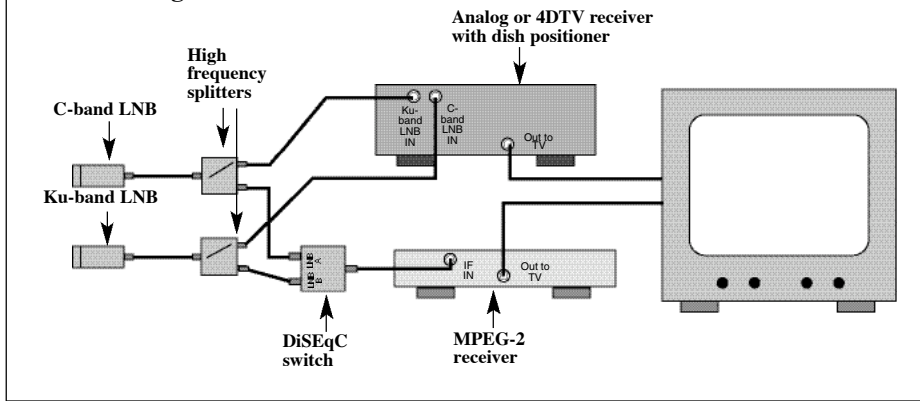

**NOTE:** If you have an analog receiver with only one LNB input and you have a C- and Ku-band LNB, you will need to place a C/Ku Switch between the LNBs (or the high frequency splitters) and the analog receiver.

#### For a system with C-band and Ku-band LNBs:

- 1) Use high-frequency splitters to split the incoming C- and Ku-band LNB signals. Be sure to hook the coax from your analog or 4DTV receiver to the output marked with the diagonal line (indicating passive one-way voltage flow) on each high-frequency splitter. Connect the coax from each splitter to the correct LNB input on the analog or 4DTV receiver (Ku-band splitter to Ku-band **L N B I N** and C-band splitter to C-band **L N B I N**).
- 2) Connect the other output on the high-frequency splitters to the A and B inputs on the DiSEqC switch, which will combine the C- and Ku-band signals and feed them to the MPEG-2 receiver through the **LNB I N** input.
- 3) If your television has more than one coaxial or A/V input, connect the MPEG-2 receiver to one of the inputs and your analog or 4DTV receiver to the other (both receivers will have a connector labeled **O U T TO TV or RF OUT**). If your television has one input, run a coaxial cable from the **O U T TO TV** connector on the MPEG-2 receiver to the **ANT I N** input on your analog or 4DTV receiver. Run a coaxial cable from **O U T TO TV or RF OUT** on the analog or 4DTV receiver to the input on your television.

### How do I program my Traxis DBS 1500 MPEG-2 receiver?

- First make sure that your Main Receiver is on the satellite you wish to scan for channels.
- Press **“Menu”** on the Traxis remote.
- Press the right arrow and then **“OK”** on **“Antenna Installation.”**
- Click **“OK”** on **“1 Uninstall.”** (Note that there are 30 different “Uninstall” locations and you will need to choose the next one down for each additional satellite when programming future satellites.)
- Using the **up** and **down** arrows on **“Satellite List”**, select then click **“OK”** on the satellite you wish to scan. The antenna information will appear.
- Down arrow to **“LNB Low Freq.”**
- Using the remote key pad, enter the corresponding LNB Frequency: **10750 for Ku-band** or **5150 for C-band**.

#### If you are using a DiSEqC switch:

- Arrow down to **DiSEqC** and use the right arrow to select **DiSEqC A** or **DiSEqC B**. If you hooked the diSEqC switch up according to our diagram, “A” would be Ku-band and “B” would be C-band.
- After entering all Antenna information, press **“Exit”** to return to **“Antenna Installation”** then press **“Exit”** again.
- Using the down arrow, select **“Satellite Scan”** and press **“OK.”**
- Press **“OK”** on the satellite you wish to scan. A checkmark will appear.
- Press the **green** button on the remote and select **“Free”** on **“Search Options.”**
- Select **“ON”** for NIT then press **“OK”** and allow the unit to scan.
- Repeat for each desired satellite and polarity.